



Project Summary

MARTA Artbound and Atlanta DOT seek two artists to design two murals. These designs will be translated into a series of stencils so the community can assist with painting the design onto a series of concrete barriers. The painted barriers will be used to create a bike lane along Lee Street in front of West End Station. [Please review these project photos for examples of this type of project.](#)

Eligibility and Evaluation Criteria

Eligible applicants will be muralists and painters who show artistic merit demonstrated in a strong portfolio of past work, as well as a willing spirit to work with the community. This opportunity is open to all metro Atlanta artists, but we particularly encourage artists to apply who live near West End station or in Southwest Atlanta. Shortlisted artists' references will be reviewed to assure that they are able to collaborate creatively with the community and project team members.

Budget

Artist Fees:

\$500 – proposal fees paid to five shortlisted artists

\$5,000 – fee awarded to two finalists. Fee to include design creation, digital file preparation for stencils, and final touch ups. Artists will also be encouraged to participate in community paint days as much as their schedule permits.

ArtzyBella Co. has been engaged to manage this project and will be responsible for supervising the paint site and community paint days. All paint supplies (paint, brushes, drop cloths, stencils, etc.) will be provided by MARTA and coordinated through ArtzyBella.

Site Description

The designated site is located along Lee Street running parallel to West End Station. The barriers (145 in total) will be painted in a parking lot at West End Station and moved into place along Lee Street during the course of the project.

Project Goals

- Commission a dynamic and engaging artwork that adds vibrancy and color to Lee Street and the neighborhood.
- Provide an anchor event for the community to take part in together.
- Use public art to reflect and build community.

Required Submittals: Application Deadline is May 22 by 12pm.

If you would like to be considered, please send the following materials via *WeTransfer.com* in **one PDF Document** to artbound@itsmarta.com. Please note that materials not sent in **one PDF** (sent as separate files) will not be reviewed.

- 5 – 10 digital images of relevant previous work in which you were the lead artist, labeled with title if applicable, and year of completion.
- A written paragraph describing a general thematic approach to the design you might propose if shortlisted. For example, will you use an abstract approach or something more figurative, what range of colors or symbols might come into play, etc.
- Current contact information (phone, email, street address) and artistic resume or bio
- Two professional references with phone and email

Selection Process - The selection process will have two phases:

Phase 1:

- Artists submit the items listed in “Required Submittals” for review by a formal Selection Panel composed of MARTA Artbound, community stakeholders and members of the arts community.
- Artist Submittals are reviewed by the Panel, and five artists will be designated as Finalists to create a proposal artwork for final review.

Phase 2:

- The five Finalists will each create a proposal artwork. Each Finalist will receive a \$500 stipend after receipt of proposal. Please note that MARTA will own all proposal artworks.
- The Selection Panel will award/commission two Artists from the shortlist to develop final artworks.
- ArtzyBella will notify Finalists of the Panel’s decision and a contract will be executed with the awarded artists. Please note that MARTA will own both the selected proposal and final artwork design by the commissioned artist.
- Proposal artworks are not considered final and MARTA Artbound may request minor changes to further refine the proposals into the final artworks.

Resource Images



Overhead view of proposed bike lane

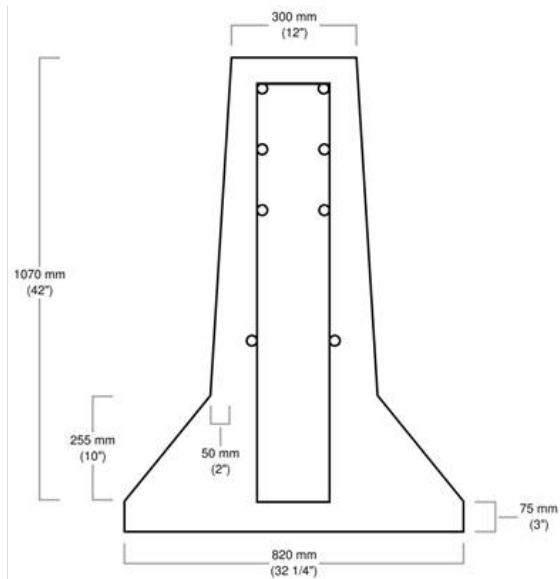

Concrete barrier and dimensions